

TITAN STAINLESS CUSTOM FOODSERVICE FABRICATION

502 Usher Street · Pageland, SC · 704-243-8717 · www.titan-stainless.com



SOILED DISHTABLE – RIGHT SIDE OF MACHINE

TITAN STAINLESS Dishtables are made using all-welded heavy gauge stainless steel construction. Assembly is not required; however, equipment can be disassembled for convenience. The backs of the tables are formed into a 9" tall x 2" thick backsplash with angled top; all other edges feature our standard 3"H raised rolled edge. Dishmachine opening is 20-3/4" standard. Reinforcing channels are applied to the underside of the top and sealed with double-sided sound dampening tape. A 20" x 20" x 8" pre-rinse sink bowl is provided along with 8" O.C. faucet holes in the backsplash (plumbing components are not provided). 1-5/8" diameter tubing is fitted into stainless steel leg sockets, which are welded to reinforcement below, preventing surface imperfections. Legs are removable, and furnished with adjustable stainless steel bullet feet. 1-5/8" diameter cross-rails are welded to the table legs. All welds are ground and polished to a smooth finish.

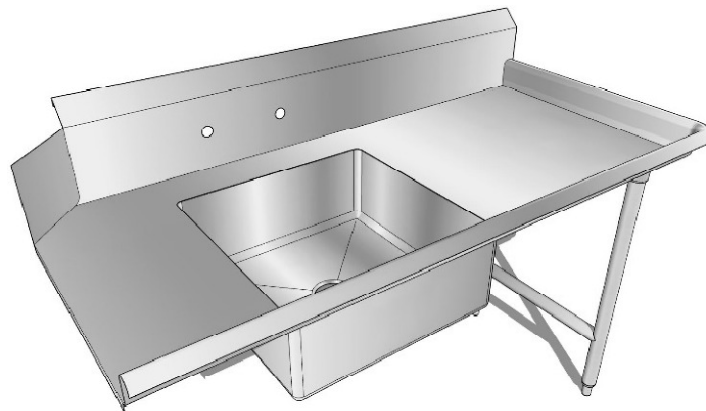

MODEL NUMBER SELECTION / INFORMATION

(Example #: 5SDT-R)

Dishtables are available in standard lengths from 3'-0" to 10'-0", in 1-foot increments. Standard width is 30" to accommodate standard commercial dishmachines. Units over 6'-0" long will be furnished with an additional set of legs.

- See **AutoQuotes™** for full list of model numbers and pricing, along with all additional accessories
- Custom sizes and configurations are available upon request

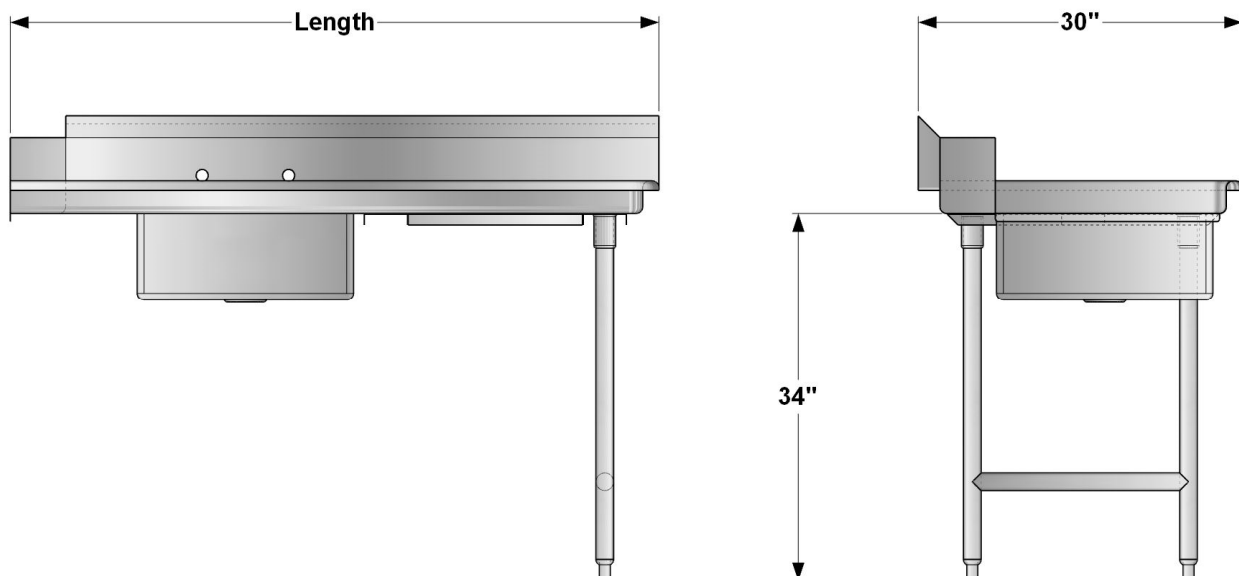

TITAN STAINLESS

502 Usher Street · PO Box 8 · Pageland, SC 29728
Contact: 704-243-8717 · quotes@titan-stainless.com · www.titan-stainless.com

