

TITAN STAINLESS CUSTOM FOODSERVICE FABRICATION



502 Usher Street Pageland, SC 704 243 8717 www.titan stainless.com

WALL CABINET WITH OPEN FRONT

TITAN STAINLESS Wall cabinets are made using all-welded heavy gauge stainless steel construction. The tops of the cabinets are sloped to prevent dust from settling, facilitating a cleaner environment. Tops are formed from one piece, and bolted to cabinet walls below. Cabinet walls are faced with 2" wide mullions, and base shelves and mid-shelves are welded between and reinforced as necessary. Cabinets are mounted to walls using heavy gauge stainless "Z" clips. All welds are ground and polished to a smooth finish.

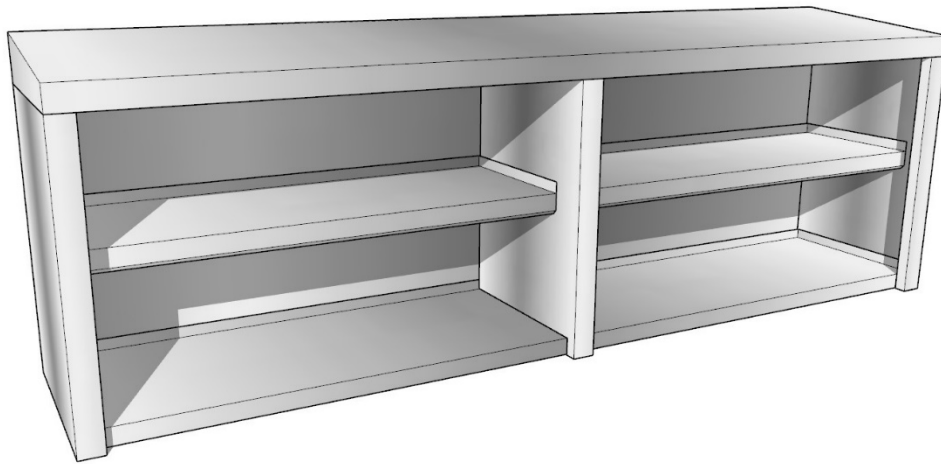

MODEL NUMBER SELECTION / INFORMATION

(Example #: 6SWC-12)

Wall cabinets are available in standard lengths from 4'-0" to 12'-0", in 1-foot increments. Standard widths (front-to-back) are available in 12" and 18". Units over 6'-0" long will be furnished with an additional cabinet wall at the center.

- See **AutoQuotes™** for full list of model numbers and pricing, along with all additional accessories
- Custom sizes and configurations are available upon request

